

PROMAX Water Filter & UV Systems

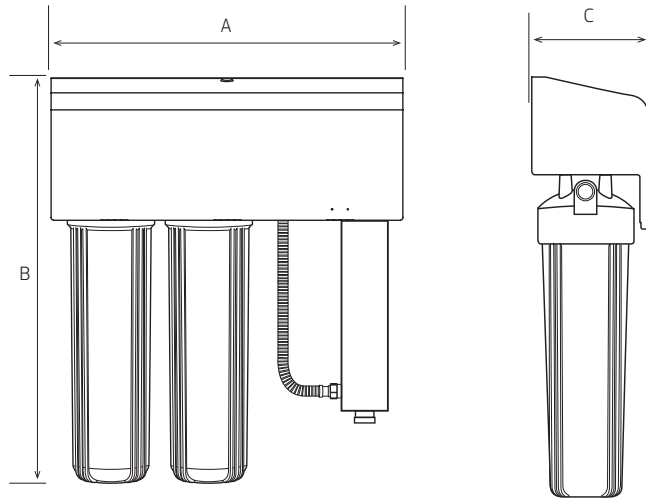

Model Number	A	B	C (Depth)
HYBRID-G8	670 mm	700 mm	211 mm
HYBRID-G9	670 mm	760 mm	211 mm



GENERAL INFO

DESIGNED FOR MAINS & RAINWATER SUPPLIES

Filtration and Ultraviolet All in One Unit with Weather Cover

Puretec Hybrid Systems provide safe and purified water at every tap. Designed for both mains and rainwater supply, this filter system is highly effective in eliminating 99.99% bacteria and parasites in your water. The Hybrid Systems also reduces silt, sludge, dirt & rust giving good general purpose filtration.

SPECIFICATIONS

Model:	Hybrid-G8	Hybrid-G9
Replacement parts and cartridges:		
1st Stage Filtration	PL20MP1	PL20MP2
2nd Stage Filtration	PX01MP1	PX01MP2
High output UV lamp, 46 W	RL6	
Flow rate	75 Lpm	130 Lpm
Maximum temperature	52°C *	
Maximum Pressure	875 kPa	
Connection:	1" BSP [25mm]	

Important Note: Use only genuine Puretec replacement cartridges. ^3 Year Platinum Protection applies to Puretec Systems when used in conjunction with a Puretec filter cartridge. Warranty excludes cartridges.

FEATURES & BENEFITS

- Dual filtration for extra sediment capacity
- High Strength Light-weight Aluminium bracket with Architectural Grade PVDF electro coating
- Fast plug & play installation
- Designed for harsh climate
- Quick and easy plug-and-play installation
- Equipped with a lamp count-down timer and alarm
- Anti-tamper & childproof lockable lid
- Hinged lid for easy access for lamp change
- 3 Year Warranty

HYBRID DOSAGE

Flow rate @40mJ/cm ²	54 Lpm
Flow rate @30mJ/cm ²	70 Lpm
Flow rate @16mJ/cm ²	130 Lpm

ADDITIONAL INFORMATION

The Hybrid Series Kills 99.99% Of Bacteria & Parasites

Thanks to its advanced UV technology – called Radfire™ – the Hybrid series kills 99.99% of tank water bacteria. Nothing else even comes close. Radfire™ is a natural water purification process, that's ecofriendly and completely chemical free. So you get safe, purified water at every outlet in the house.

It Filters Your Water Too

As its name suggests, the Hybrid series combines two technologies to clean your water. In addition to killing 99.99% of bacteria with UV rays, it filters out sediment and anything else that manages to pass through your rainwater tank's coarser filter. This not only makes your water safe, but also prolongs the life of your household appliances.

Longer Filter Life

The Hybrid series incorporates Puretec's long life filter technology, so you can go longer between filter replacements, and comes with our **3 Year Platinum Protection Warranty**^.

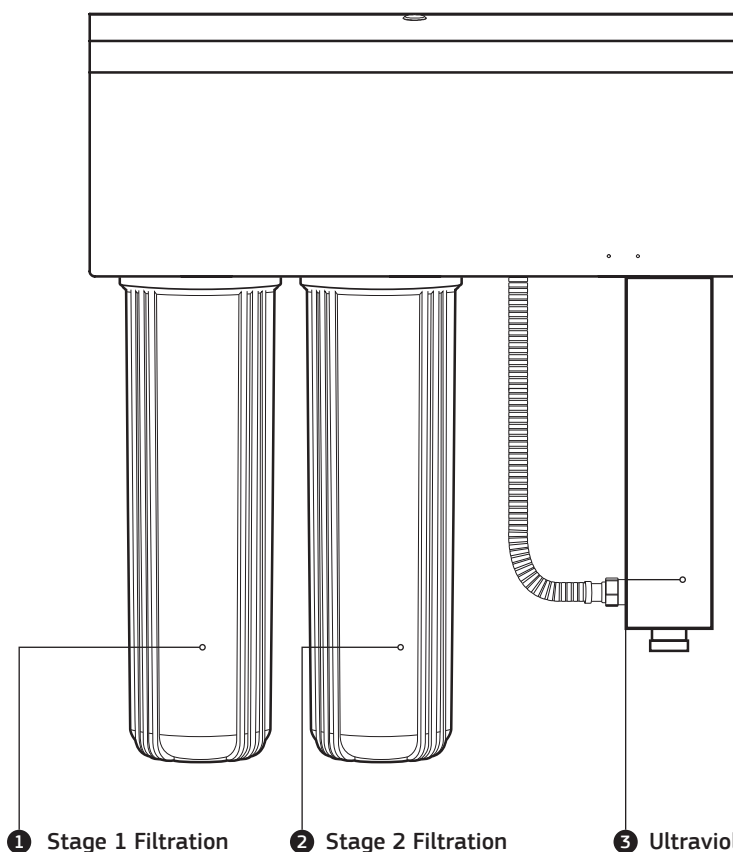

Features & Benefits

Weather-proof Cover

Light-weight Aluminium bracket with Architectural Grade PVDF electro coating

Weather Protection

The Hybrid incorporates a weather cover for outdoor installations

Excellent Corrosion Resistance

Constructed using high strength aluminium bracket, lid and stainless chamber ensures no rusting

Easy Installation

4 mounting points for quick and easy installation

Neatly Concealed Monitor Panel

Monitors the lamp life, failure alarm (audible & visible) and total running days of the Radfire UV unit

Anti-Tamper Design

Anti-tamper and childproof lockable lid

1 Stage 1 Filtration

A washable 20 micron sediment filter to remove silt, sludge, dirt, rust and other coarse particles

2 Stage 2 Filtration

A solid 1 micron filter to remove fine particles

3 Ultraviolet Protection

Kills 99.99% of bacteria with Radfire ultraviolet technology, a natural purification process that's completely eco-friendly and chemical-free