

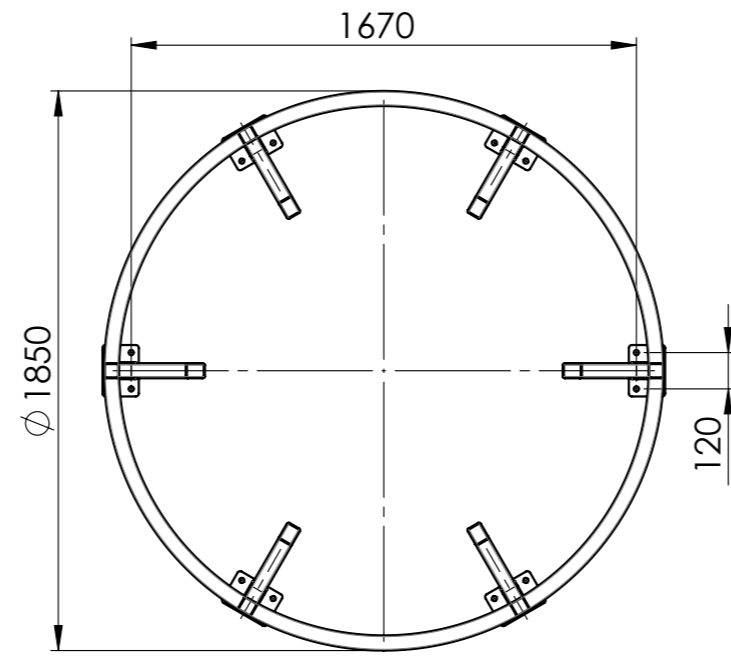

8 7 6 5 4 3 2 1

F
E
D
C
B
A

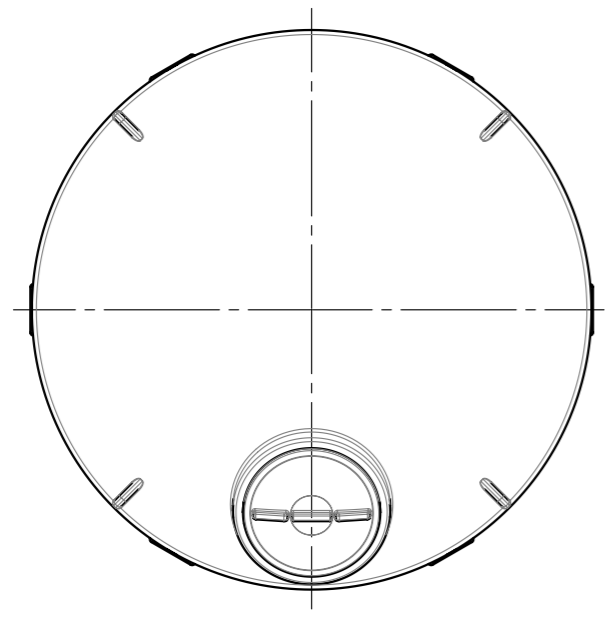
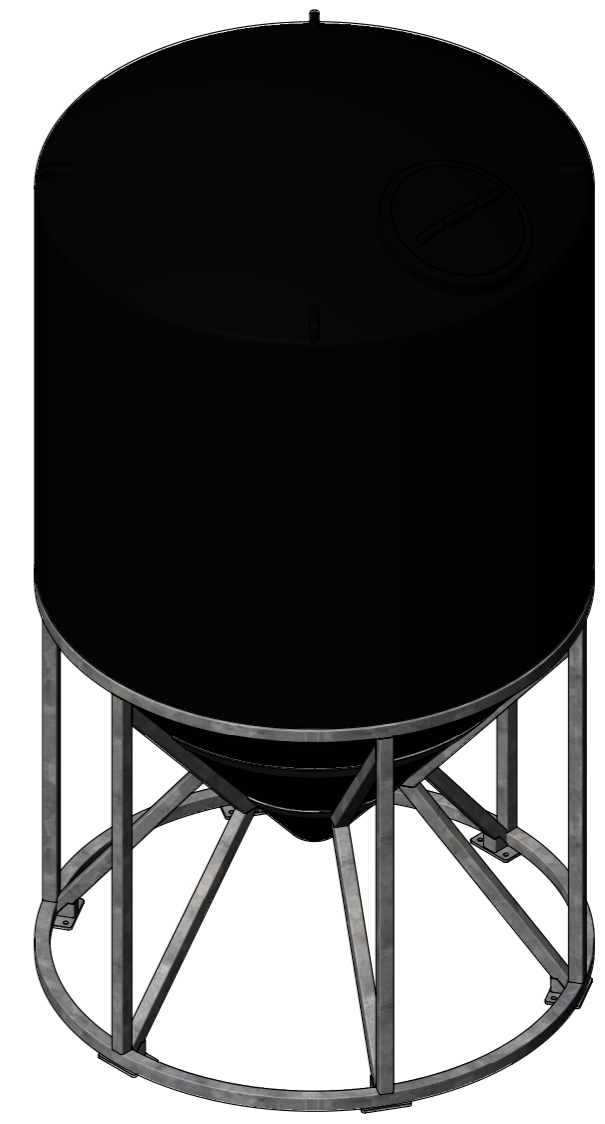
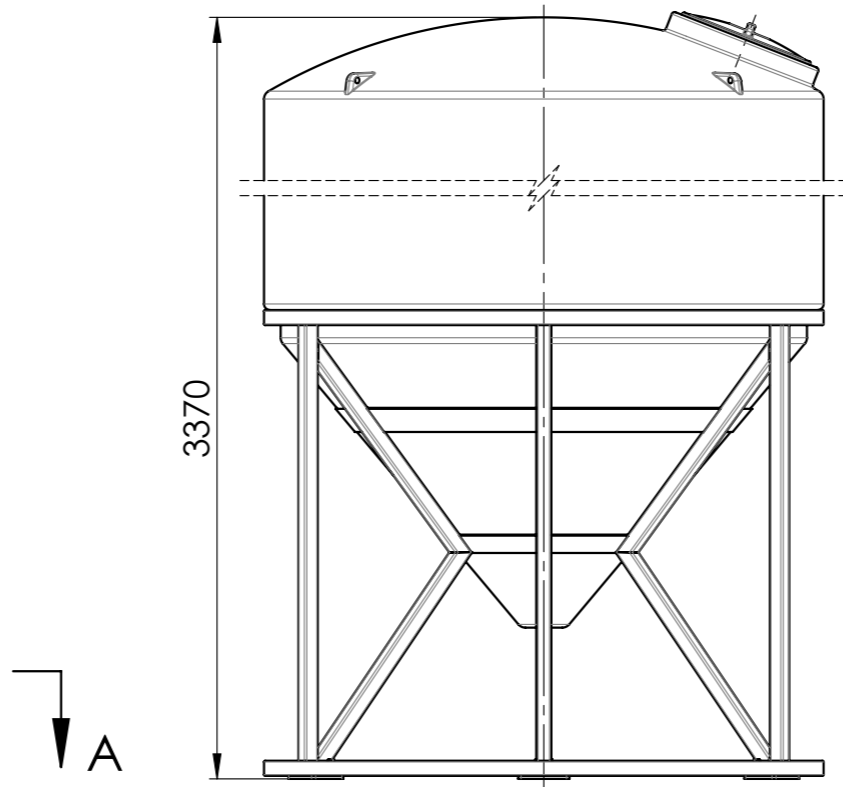
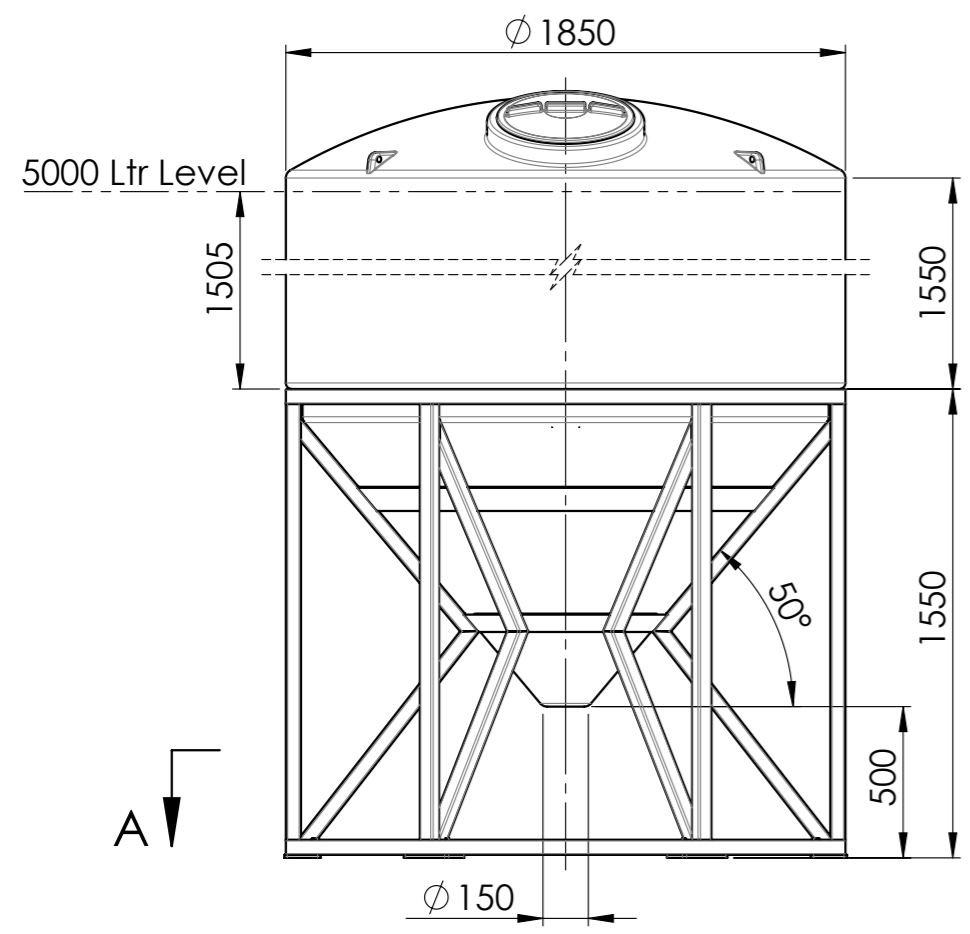

SECTION A-A

CLIENT APPROVAL <input type="checkbox"/> APPROVED <input type="checkbox"/> REVISE AND RESUBMIT <input type="checkbox"/> FOR INFORMATION ONLY DATE:		SIGNATURE 		 Promax <small>LIQUID MANAGEMENT SOLUTIONS</small> PROPRIETARY AND CONFIDENTIAL <small>THIS DRAWING AND THE INFORMATION AND TECHNICAL DATA CONTAINED HEREIN ARE THE EXCLUSIVE PROPERTY OF PROMAX PLASTICS AND SHALL BE RETURNED TO THEM UPON REQUEST. THIS DRAWING CONTAINS PROPRIETARY AND CONFIDENTIAL INFORMATION FOR THIS PROJECT AND IS NOT TO BE MADE AVAILABLE TO 3RD PARTIES WITHOUT THE EXPRESS WRITTEN CONSENT OF PROMAX PLASTICS.</small>		DO NOT SCALE DRAWING ORIGINAL ISSUE:		OPP: AUTHOR: SL MATERIAL: WEIGHT:		DISPLAY NAME/NUMBER: EXPRESS Industrial Cone Tank 5000 Ltr DWG NO. XICT05000-NI SCALE: 1:25 SHEET 1 OF 1	
---	--	--------------------------	--	---	--	---	--	--	--	---	--

A3

8 7 6 5 4 3 2 1