

Job Customer:

Title:

Ref:

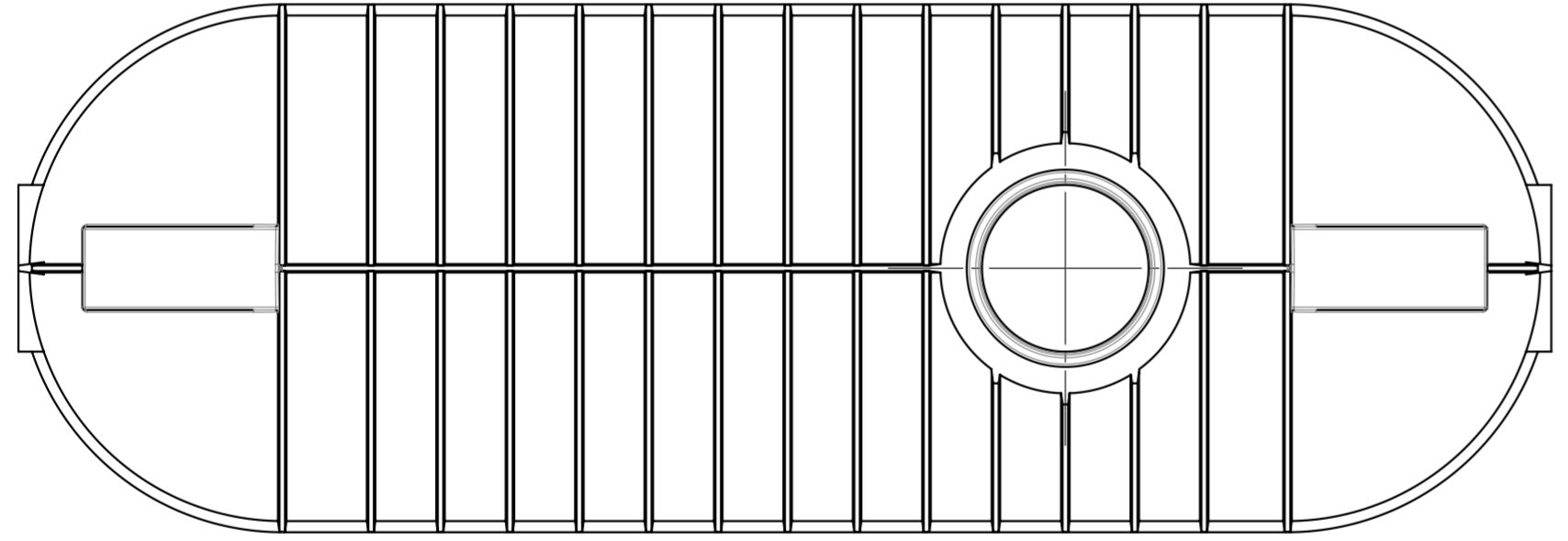
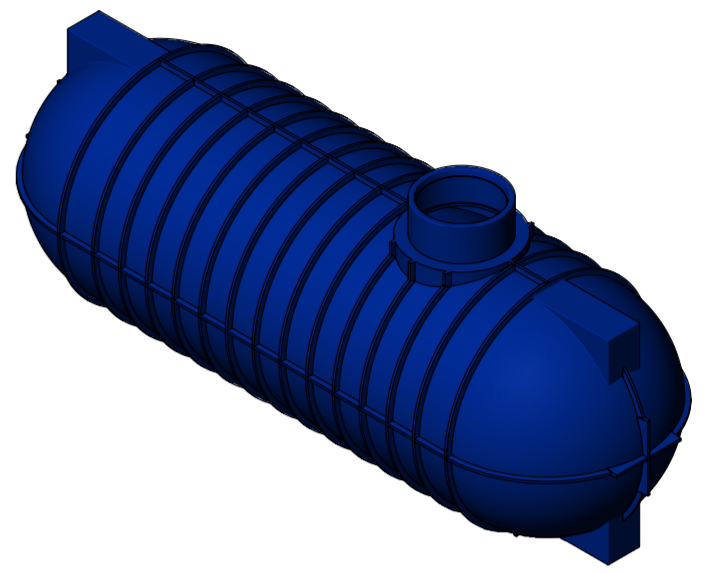
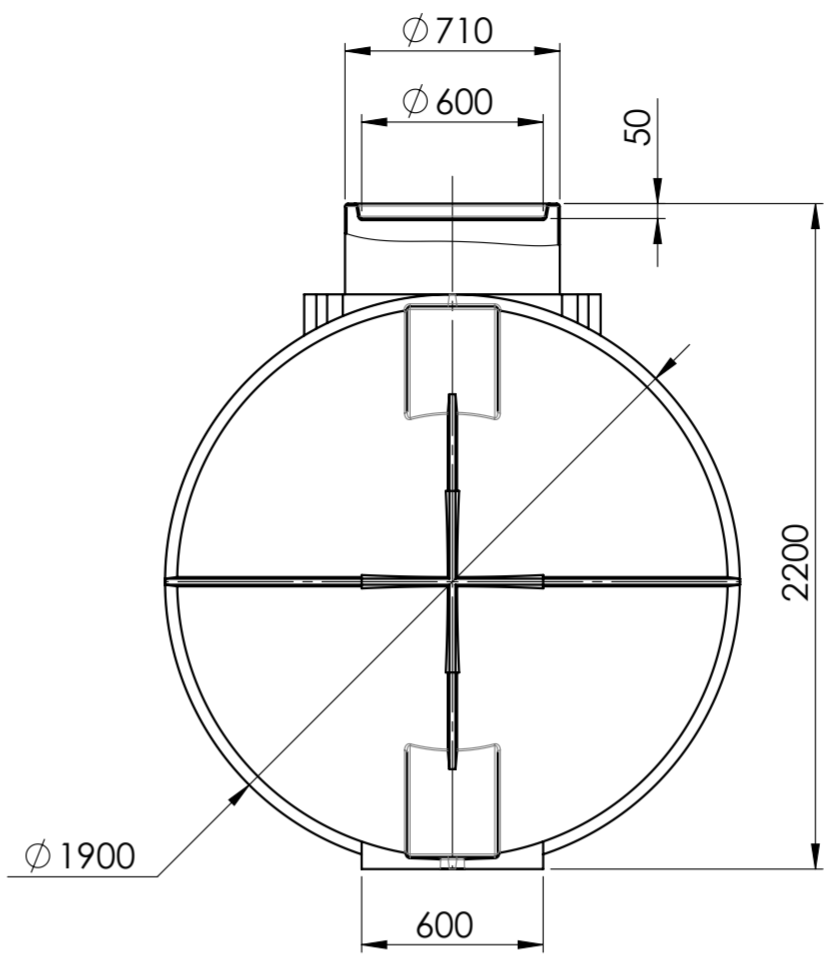
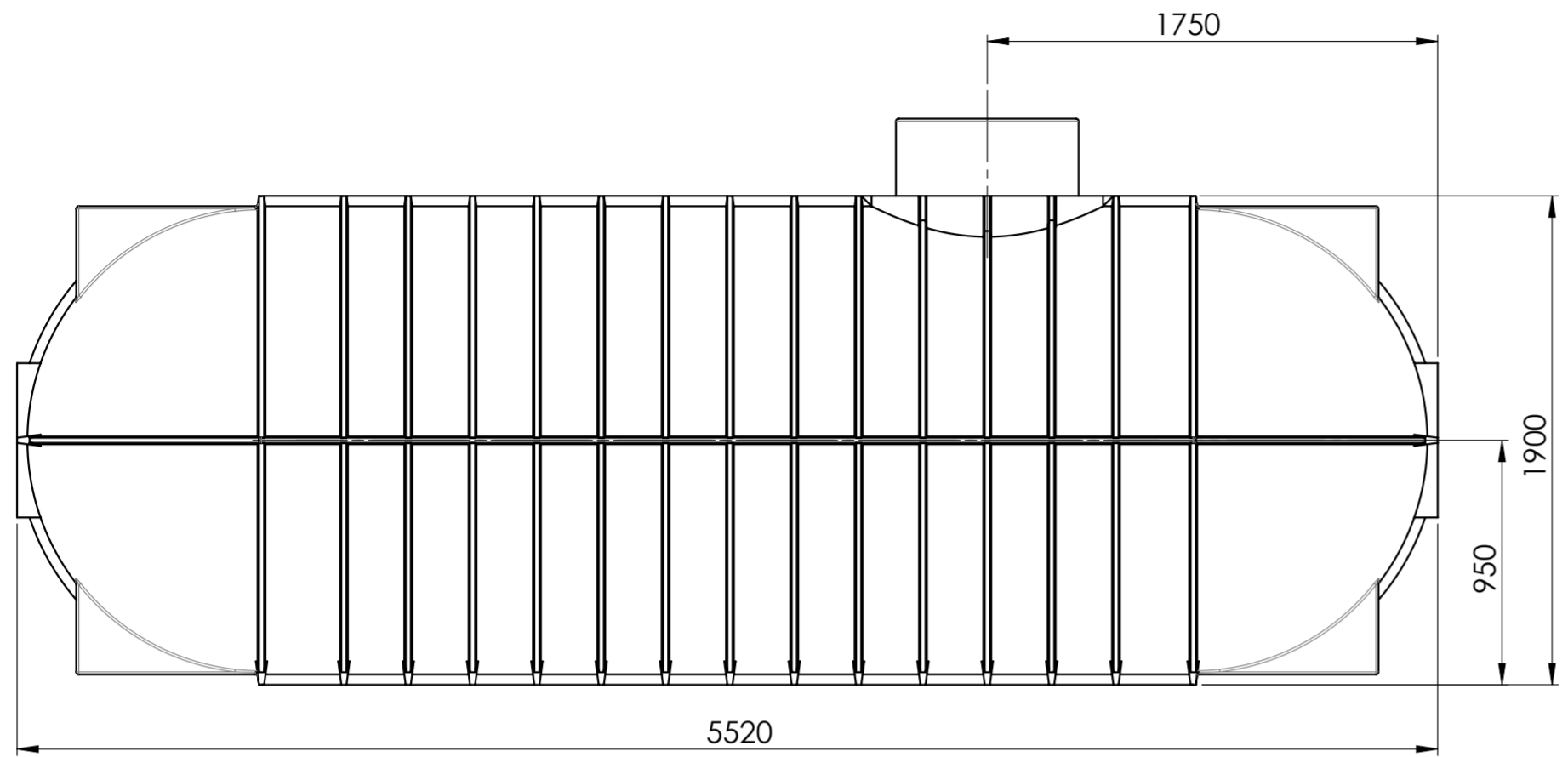

FITTINGS LAYOUT TABLE

NOZZLE No	PE SIZE	LEVEL MARK	ANGLE	DESCRIPTION
N1				
N2				
N3				
N4				
N5				
N6				
N7				
N8				

NOTES:

1. LEVEL MARKS ARE IN m, DIMENSIONS ARE IN mm.

DATE	CLIENT APPROVAL SIGNATURE	UNLESS OTHERWISE SPECIFIED: DIMENSIONS ARE IN MILLIMETERS SURFACE FINISH: TOLERANCES: LINEAR: ANGULAR:	FINISH:	DEBURR AND BREAK SHARP EDGES	DO NOT SCALE DRAWING	REVISION
		DRAWN	NAME	SIGNATURE	DATE	TITLE: 10000L UNDERGROUND TANK (UX1910000) NOZZLES LAYOUT
		CHK'D				DWG NO.
		APPV'D				A2
		MFG				SCALE: 1:25
		Q.A.				SHEET 1 OF 1
				MATERIAL:		
				WEIGHT:		